

14

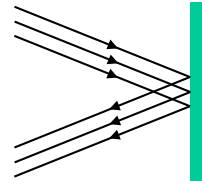

ECHO CANCELLATION

- 14.1 Introduction: Acoustic and Hybrid Echoes
- 14.2 Telephone Line Hybrid Echo
- 14.3 Hybrid Echo Suppression
- 14.4 Adaptive Echo Cancellation
- 14.5 Acoustic Echo
- 14.6 Sub-band Acoustic Echo Cancellation
- 14.7 Summary

Echo is the repetition of a waveform due to reflection from points where the characteristics of the medium through which the wave propagates changes. Echo is usefully employed in sonar and radar for detection and exploration purposes. In telecommunication, echo can degrade the quality of service, and echo cancellation is an important part of communication systems. The development of echo reduction began in the late 1950s, and continues today as new integrated landline and wireless cellular networks put additional requirement on the performance of echo cancellers. There are two types of echo in communication systems: acoustic echo and telephone line hybrid echo. Acoustic echo results from a feedback path set up between the speaker and the microphone in a mobile phone, hands-free phone, teleconference or hearing aid system. Acoustic echo may be reflected from a multitude of different surfaces, such as walls, ceilings and floors, and travels through different paths. Telephone line echoes result from an impedance mismatch at telephone exchange hybrids where the subscriber's 2-wire line is connected to a 4-wire line. The perceptual effects of an echo depend on the time delay between the incident and reflected waves, the strength of the reflected waves, and the number of paths through which the waves are reflected. Telephone line echoes, and acoustic feedback echoes in teleconference and hearing aid systems, are undesirable and annoying and can be disruptive. In this chapter we study some methods for removing line echo from telephone and data telecommunication systems, and acoustic feedback echoes from microphone–loudspeaker systems.

14.1 Introduction: Acoustic and Hybrid Echoes

Echo can severely affect the quality and intelligibility of voice conversation in a telephone system. The perceived effect of an echo depends on its amplitude and time delay. In general, echoes with an appreciable amplitude and a delay of more than 1 ms are noticeable. Provided the round-trip delay is on the order of a few milliseconds, echo gives a telephone call a sense of “liveliness”. However, echoes become increasingly annoying and objectionable with the increasing round-trip delay and amplitude in particular for delays of more than 20 ms. Hence echo cancellation is an important aspect of the design of modern telecommunication systems such as conventional wireline telephones, hands-free phones, cellular mobile (wireless) phones, or teleconference systems. There are two types of echo in a telephone system (Figure 14.1):

- (a) acoustic echo due to acoustic coupling between the speaker and the microphone in hands-free phones, mobile phones and teleconference systems;
- (b) electrical line echo due to mismatch at the hybrid circuit connecting a 2-wire subscriber line to a 4-wire trunk line in the public switched telephone network.

In the early days of expansion of telephone networks, the cost of running a 4-wire line from the local exchange to subscribers’ premises was considered uneconomical. Hence, at the exchange the 4-wire trunk lines are converted to 2-wire subscribers local lines using a 2/4-wire hybrid bridge circuit. At the receiver due to any imbalance between the 4/2-wire bridge

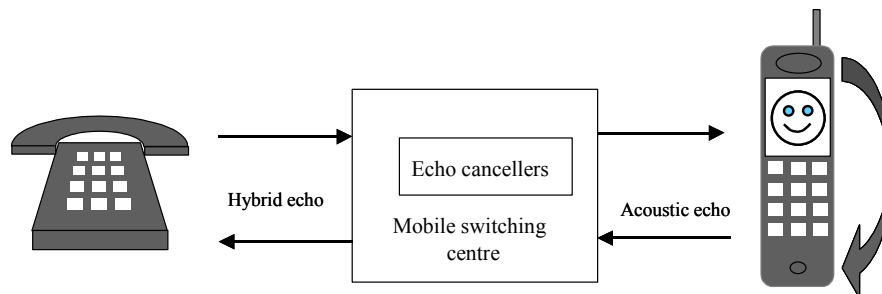

Figure 14.1 Illustration of echo in a mobile to land line system.

circuit, some of the signal energy of the 4-wire circuit is bounced back towards the transmitter, constituting an echo signal. If the echo is more than a few milliseconds long then it becomes noticeable, and can be annoying and disruptive.

In digital mobile phone systems, the voice signals are processed at two points in the network: first voice signals are digitised, compressed and coded within the mobile handset, and then processed at the radio frequency interface of the network. The total delay introduced by the various stages of digital signal processing range from 80 ms to 100 ms, resulting in a total round-trip delay of 160–200 ms for any echo. A delay of this magnitude will make any appreciable echo disruptive to the communication process. Owing to the inherent processing delay in digital mobile communication systems, it is essential and mandatory to employ echo cancellers in mobile phone switching centres.

14.2 Telephone Line Hybrid Echo

Hybrid echo is the main source of echo generated from the public-switched telephone network (PSTN). Echoes on a telephone line are due to the reflection of signals at the points of impedance mismatch on the connecting circuits. Conventionally, telephones in a given geographical area are connected to an exchange by a 2-wire twisted line, called the subscriber's linline, which serves to receive and transmit signals. In a conventional system a local call is set up by establishing a direct connection, at the telephone exchange, between two subscribers' loops. For a local call, there is usually no noticeable echo either because there is not a significant impedance mismatch on the connecting 2-wire local lines or because the

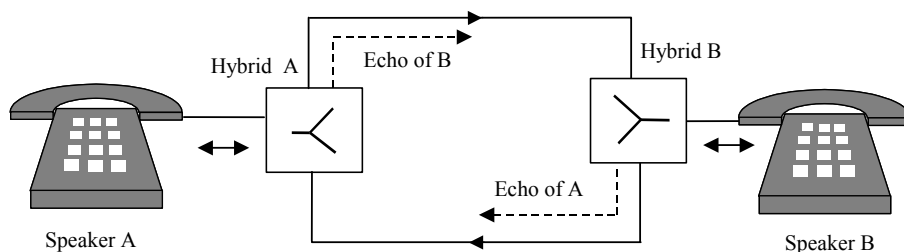

Figure 14.2 Illustration of a telephone call set up by connection of 2-wire subscriber's via hybrids to 4-wire lines at the exchange.

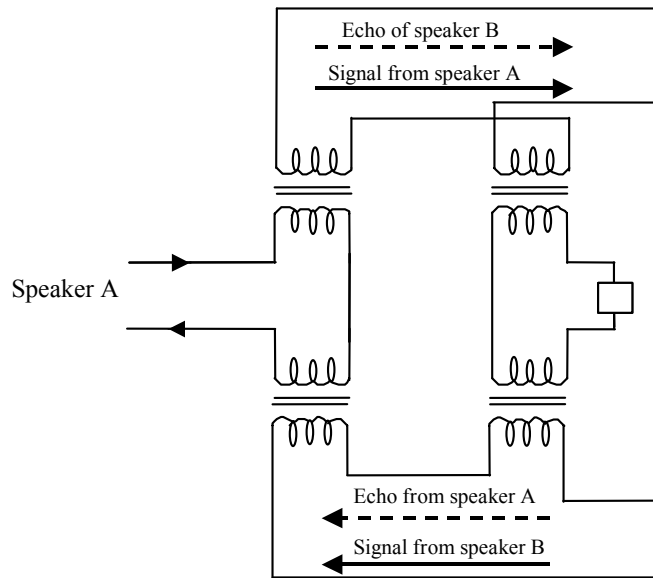

Figure 14.3 A 2-wire to 4-wire hybrid circuit.

distances are relatively small and the resulting low-delay echoes are perceived as a slight amplification and “livening” effect. For long-distance communication between two exchanges, it is necessary to use repeaters to amplify the speech signals; therefore a separate 2-wire telephone line is required for each direction of transmission.

To establish a long-distance call, at each end, a 2-wire subscriber's line must be connected to a 4-wire line at the exchange, as illustrated in Figure 14.2. The device that connects the 2-wire subscriber's loop to the 4-wire line is called a hybrid, and is shown in Figure 14.3. As shown the hybrid is basically a three-port bridge circuit. If the hybrid bridge were perfectly balanced then there would be no reflection or echo. However, each hybrid circuit serves a number of subscribers' lines. The subscribers' lines do not all have the same length and impedance characteristics; therefore it is not possible to achieve perfect balance for all subscribers at the hybrids. When the bridge is not perfectly balanced, some of the signal energy on the receiving 4-wire lines becomes coupled back onto itself and produces an echo. Echo is often measured in terms of the echo return loss (ERL); the higher the echo return loss the lower will be the echo. Telephone line echoes are undesirable, and become annoying when the echo amplitude is relatively high and the echo delay is long. For example when a long-

distance call is made via a satellite the round-trip echo delay can be as long as 600 ms, and echoes can become disruptive. Also, as already mentioned, there are appreciable delays of up to 200 ms inherent in digital mobile phones, which make any echo quite noticeable. For this reason the employment of echo cancellers in mobile switching centres is mandatory.

14.3 Hybrid Echo Suppression

The development of echo reduction began in the late 1950s with the advent of echo suppression systems. Echo suppressors were first employed to manage the echo generated primarily in satellite circuits. An echo suppressor (Figure 14.4) is primarily a switch that lets the speech signal through during the speech-active periods and attenuates the line echo during the speech-inactive periods. A line echo suppressor is controlled by a speech/echo detection device. The echo detector monitors the signal levels on the incoming and outgoing lines, and decides if the signal on a line from, say, speaker B to speaker A is the speech from the speaker B to the speaker A, or the echo of speaker A. If the echo detector decides that the signal is an echo then the signal is heavily attenuated. There is a similar echo suppression unit from speaker A to speaker B. The performance of an echo suppressor depends on the accuracy of the echo/speech classification subsystem. Echo of speech often has a smaller amplitude level than the speech signal, but otherwise it has mainly the same spectral characteristics

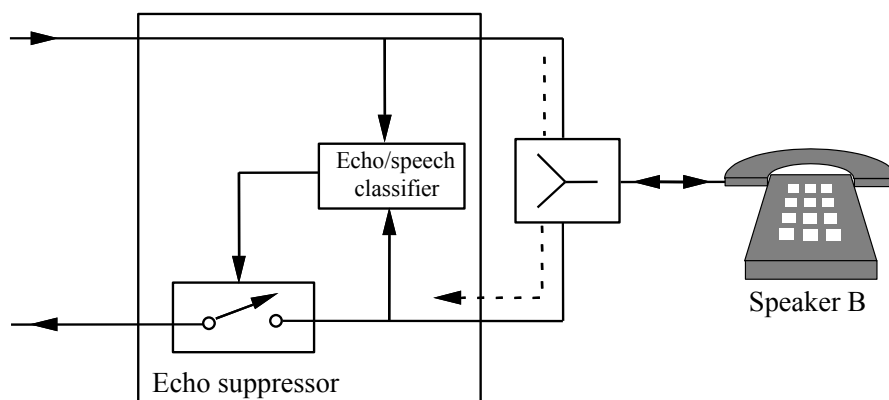

Figure 14.4 Block diagram illustration of an echo suppression system.

and statistics as those of the speech. Therefore the only basis for discrimination of speech from echo is the signal level. As a result, the speech/echo classifier may wrongly classify and let through high-level echoes as speech, or attenuate low-level speech as echo. For terrestrial circuits, echo suppressers have been well designed, with an acceptable level of false decisions and a good performance. The performance of an echo suppresser depends on the time delay of the echo. In general, echo suppressers perform well when the round-trip delay of the echo is less than 100 ms. For a conversation routed via a geostationary satellite the round-trip delay may be as much as 600 ms. Such long delays can change the pattern of conversation and result in a significant increase in speech/echo classification errors. When the delay is long, echo suppressers fail to perform satisfactorily, and this results in choppy first syllables and artificial volume adjustment. A system that is effective with both short and long time delays is the adaptive echo canceller introduced next.

14.4 Adaptive Echo Cancellation

Echo cancellation was developed in the early 1960s by AT&T Bell Labs and later by COMSAT TeleSystems. The first echo cancellation systems were experimentally implemented across satellite communication networks to demonstrate network performance for long-distance calls.

Figure 14.5 illustrates the operation of an adaptive line echo canceller. The speech signal on the line from speaker A to speaker B is input to the 4/2 wire hybrid B and to the echo canceller. The echo canceller monitors the signal on line from B to A and attempts to model and synthesis a replica of the echo of speaker A. This replica is used to subtract and cancel out the echo of speaker A on the line from B to A. The echo canceller is basically an adaptive linear filter. The coefficients of the filter are adapted so that the energy of the signal on the line is minimised. The echo canceller can be an infinite impulse response (IIR) or a finite impulse response (FIR) filter. The main advantage of an IIR filter is that a long-delay echo can be synthesised by a relatively small number of filter coefficients. In practice, echo cancellers are based on FIR filters. This is mainly due to the practical difficulties associated with the adaptation and stable operation of adaptive IIR filters.

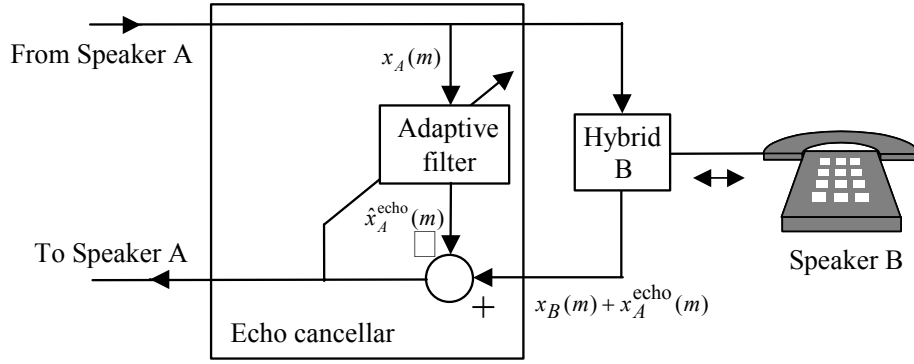

Figure 14.5 Block diagram illustration of an adaptive echo cancellation system.

Assuming that the signal on the line from speaker B to speaker A, $y_B(m)$, is composed of the speech of speaker B, $x_B(m)$, plus the echo of speaker A, $x_A^{\text{echo}}(m)$, we have

$$y_B(m) = x_B(m) + x_A^{\text{echo}}(m) \quad (14.1)$$

In practice, speech and echo signals are not simultaneously present on a phone line. This, as pointed out shortly, can be used to simplify the adaptation process. Assuming that the echo synthesiser is an FIR filter, the filter output estimate of the echo signal can be expressed as

$$\hat{x}_A^{\text{echo}}(m) = \sum_{k=0}^{P-1} w_k(m) x_A(m-k) \quad (14.2)$$

where $w_k(m)$ are the time-varying coefficients of an adaptive FIR filter and $\hat{x}_A^{\text{echo}}(m)$ is an estimate of the echo of speaker A on the line from speaker B to speaker A. The residual echo signal, or the error signal, after echo subtraction is given by

$$\begin{aligned} e(m) &= y_B(m) - \hat{x}_A^{\text{echo}}(m) \\ &= x_B(m) + x_A^{\text{echo}}(m) - \sum_{k=0}^{P-1} w_k(m) x_A(m-k) \end{aligned} \quad (14.3)$$

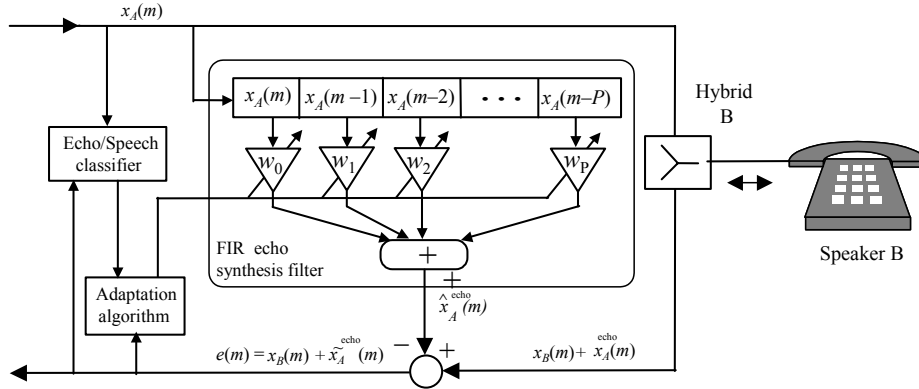

Figure 14.6 Illustration of an echo canceller using an adaptive FIR filter and incorporation a echo/speech classifier.

For those time instants when speaker A is talking, and speaker B is listening and silent, and only echo is present from line B to A, we have

$$\begin{aligned}
 e(m) &= \tilde{x}_A^{\text{echo}}(m) = x_A^{\text{echo}}(m) - \hat{x}_A^{\text{echo}}(m) \\
 &= x_A^{\text{echo}}(m) - \sum_{k=0}^{P-1} w_k(m) x_A(m-k)
 \end{aligned} \tag{14.4}$$

where $\tilde{x}_A^{\text{echo}}(m)$ is the residual echo. An echo canceller using an adaptive FIR filter is illustrated in Figure 14.6. The magnitude of the residual echo depends on the ability of the echo canceller to synthesise a replica of the echo, and this in turn depends on the adaptation algorithm discussed next.

14.4.1 Echo Canceller Adaptation Methods

The echo canceller coefficients $w_k(m)$ are adapted to minimise the energy of the echo signal on a telephone line, say from speaker B to speaker A. Assuming that the speech signals $x_A(m)$ and $x_B(m)$ are uncorrelated, the energy on the telephone line from B to A is minimised when the echo canceller output $\hat{x}_A^{\text{echo}}(m)$ is equal to the echo $x_A^{\text{echo}}(m)$ on the line. The echo canceller coefficients may be adapted using one of the variants of the recursive least square error (RLS) or the least mean squared error (LMS)

adaptation methods. One of the most widely used algorithms for adaptation of the coefficients of an echo canceller is the normalised least mean square error (NLMS) method. The time-update equation describing the adaptation of the filter coefficient vector is

$$\mathbf{w}(m) = \mathbf{w}(m-1) + \mu \frac{e(m)}{\mathbf{x}(m)_A^T \mathbf{x}_A(m)} \mathbf{x}_A(m) \quad (14.5)$$

where $\mathbf{x}_A(m) = [x_A(m), \dots, x_A(m-P)]$ and $\mathbf{w}(m) = [w_0(m), \dots, w_{P-1}(m)]$ are the input signal vector and the coefficient vector of the echo canceller, and $e(m)$ is the difference between the signal on the echo line and the output of the echo synthesiser. Note that the normalising quantity $\mathbf{x}(m)_A^T \mathbf{x}_A(m)$ is the energy of the input speech to the adaptive filter. The scalar μ is the adaptation step size, and controls the speed of convergence, the steady-state error and the stability of the adaptation process.

14.4.2 Convergence of Line Echo Canceller

For satisfactory performance, the echo canceller should have a fast convergence rate, so that it can adequately track changes in the telephone line and the signal characteristics. The convergence of an echo canceller is affected by the following factors:

- (a) *Non-stationary characteristics of telephone line and speech.* The echo characteristics depend on the impedance mismatch between the subscribers loop and the hybrids. Any changes in the connecting paths affect the echo characteristics and the convergence process. Also as explained in Chapter 7, the non-stationary character and the eigenvalue spread of the input speech signal of an LMS adaptive filter affect the convergence rates of the filter coefficients.
- (b) *Simultaneous conversation.* In a telephone conversation, usually the talkers do not speak simultaneously, and hence speech and echo are seldom present on a line at the same time. This observation simplifies the echo cancellation problem and substantially aids the correct functioning of adaptive echo cancellers. Problems arise during the periods when both speakers talk at the same time. This is because speech and its echo have similar characteristics and occupy basically the same bandwidth. When

the reference signal contains both echo and speech, the adaptation process can lose track, and the echo cancellation process can attempt to cancel out and distort the speech signal. One method of avoiding this problem is to use a speech activity detector, and freeze the adaptation process during periods when speech and echo are simultaneously present on a line, as shown in Figure 14.6. In this system, the effect of a speech/echo misclassification is that the echo may not be optimally cancelled out. This is more acceptable than is the case in echo suppressors, where the effect of a misclassification is the suppression and loss of a part of the speech.

- (c) *The adaptation algorithm.* Most echo cancellers use variants of the LMS adaptation algorithm. The attractions of the LMS are its relatively low memory and computational requirements and its ease of implementation and monitoring. The main drawback of LMS is that it can be sensitive to the eigenvalue spread of the input signal and is not particularly fast in its convergence rate. However, in practice, LMS adaptation has produced effective line echo cancellation systems. The recursive least square (RLS) error methods have a faster convergence rate and a better minimum mean square error performance. With the increasing availability of low-cost high-speed dedicated DSP processors, implementation of higher-performance and computationally intensive echo cancellers based on RLS are now feasible.

14.4.3 Echo Cancellation for Digital Data Transmission

Echo cancellation becomes more complex with the increasing integration of wireline telephone systems and mobile cellular systems, and the use of digital transmission methods such as asynchronous transfer mode (ATM) for integrated transmission of data, image and voice. For example, in ATM based systems, the voice transmission delay varies depending on the route taken by the cells that carry the voice signals. This variable delay added to the delay inherent in digital voice coding complicates the echo cancellation process.

The 2-wire subscriber telephone lines that were originally intended to carry relatively low-bandwidth voice signals are now used to provide telephone users with high-speed digital data links and digital services such as video-on-demand and internet services using digital transmission methods such as the asynchronous digital subscriber line (ADSL).

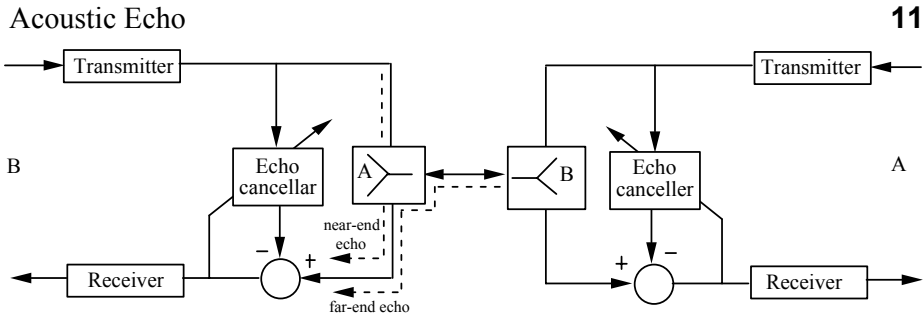

Figure 14.7 Echo cancellation in digital modems using 2-wire subscriber's loop.

Traditionally, the bandwidth of the subscribers line is limited by low-pass filters at the core network to 3.4 kHz. Within this bandwidth, voice-band modems can provide data rates of around 30 kilobits per second (kbps). However the copper wire itself has a much higher usable bandwidth extending into megahertz regions, although attenuation and interference increase with both the frequency and the length of the wire. Using advanced signal processing and modulation schemes methods such as ADSL can achieve a 10 megabits per second data rate over 240 MHz bandwidth of subscriber's twisted wire line.

Figure 14.7 shows a system for providing a full-duplex digital service over a 2-wire subscriber's loop. To provide simultaneous transmission of data in both directions within the same bandwidth over the subscriber's line, echo cancellation is needed. The echoes on a line consist of the near-end echo which loops back at the first or the near hybrid, and the far-end echo which is the signal that loops back at a hybrid some distance away. The main purpose of the echo canceller is to cancel the near-end echo. Since the digital signal coming from a far-end may be attenuated by 40–50 dB, the near echo on a high speed data transmission line can be as much as 40–50 dB above the desired signal level. For reliable data communication the echo canceller must provide 50–60 dB attenuation of the echo signal so that the signal power remains at 10 dB above the echo.

14.5 Acoustic Echo

Acoustic echo results from a feedback path set up between the speaker and the microphone in a mobile phone, hands-free phone, teleconference or hearing aid system. Acoustic echo is usually reflected from a multitude of different surfaces, such as walls, ceilings and floors, and travels through different paths. If the time delay is not too long then the acoustic echo may

be perceived as a soft reverberation, and may add to the artistic quality of the sound. Concert halls and church halls with desirable reverberation characteristics can enhance the quality of a musical performance. However, acoustic echo is a well-known problem with hands-free telephones, teleconference systems, public address systems, mobile phones, and hearing aids, and is due to acoustic feedback coupling of sound waves between the loudspeakers and microphones. Acoustic echo can result from a combination of direct acoustic coupling and multipath effect where the sound wave is reflected from various surfaces and then picked up by the microphone. In its worst case, acoustic feedback can result in howling if a significant proportion of the sound energy transmitted by the loudspeaker is received back at the microphone and circulated in the feedback loop. The overall round gain of an acoustic feedback loop depends on the frequency responses of the electrical and the acoustic signal paths. The undesirable effects of the electrical sections on the acoustic feedback can be reduced by designing systems that have a flat frequency response. The main problem is in the acoustic feedback path and the reverberating characteristics of the room. If the microphone–speaker–room system is excited at a frequency whose loop gain is greater than unity then the signal is amplified each time it circulates round the loop, and feedback howling results. In practice, the howling is limited by the non-linearity of the electronic system.

There are a number of methods for removing acoustic feedback. One method for alleviating the effects of acoustic feedback and the room reverberations is to place a frequency shifter (or a phase shifter) in the electrical path of the feedback loop. Each time a signal travels round the feedback loop it is shifted by a few hertz before being re-transmitted by the loudspeaker. This method has some effect in reducing the howling but it is not effective for removal of the overall echo of the acoustic feedback. Another approach is to reduce the feedback loop-gain at those frequencies where the acoustic feedback energy is concentrated. This may be achieved by using adaptive notch filters to reduce the system gain at frequencies where acoustic oscillations occur. The drawback of this method is that in addition to reducing the feedback the notch filters also result in distortion of the desired signal frequencies.

The most effective method of acoustic feedback removal is the use of an adaptive feedback cancellation system. Figure 14.8 illustrates a model of an acoustic feedback environment, comprising a microphone, a loudspeaker and the reverberating space of a room. The z -transfer function of a linear model of the acoustic feedback environment may be expressed as

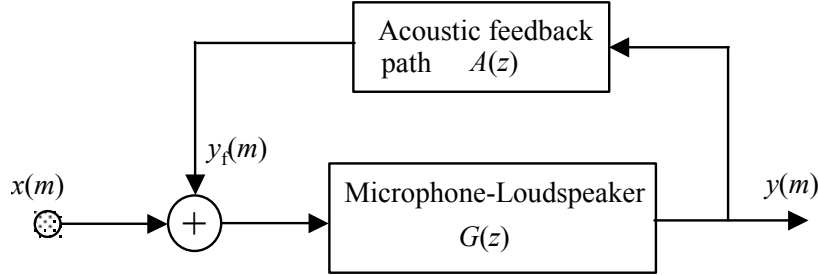

Figure 14.8 Configuration of a feedback model for a microphone–loudspeaker–room system.

$$H(z) = \frac{G(z)}{1 - G(z)A(z)} \quad (14.6)$$

where $G(z)$ is the z -transfer function model for the microphone–loudspeaker system and $A(z)$ is the z -transfer function model of reverberations and multi-path reflections of a room environment. Assuming that the microphone–loudspeaker combination has a flat frequency response with a gain of G , Equation (14.6) can be simplified to

$$H(z) = \frac{G}{1 - G A(z)} \quad (14.7)$$

Note that in Equation (14.6), owing to the reverberating character of the room, the acoustic feedback path $A(z)$ is itself a feedback system. The reverberating characteristics of the acoustic environment may be modelled by an all-pole linear predictive model, or alternatively a relatively long FIR model.

The equivalent time-domain input/output relation for the linear filter model of Equation (14.7) is given by the following difference equation:

$$y(m) = G \sum_{k=0}^{P-1} a_k(m) y(m-k) + G x(m) \quad (14.8)$$

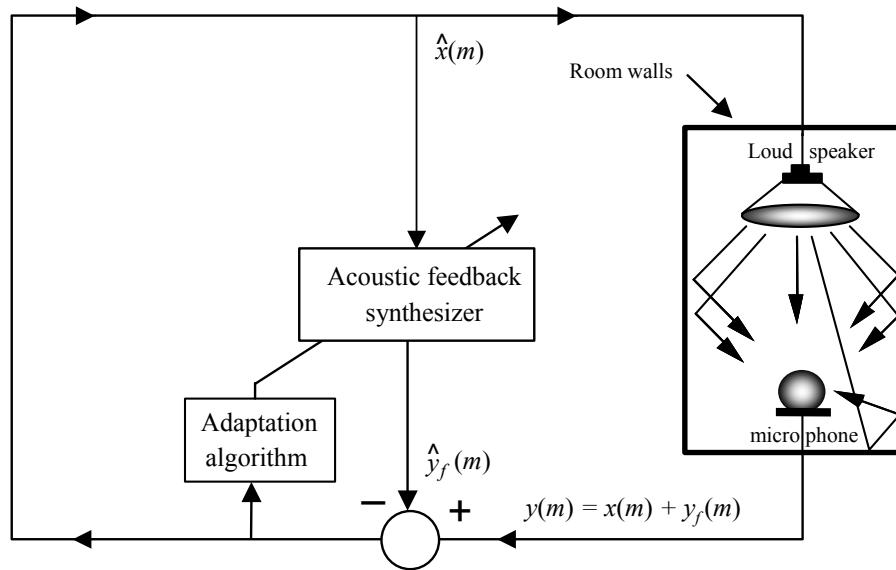

Figure 14.9 Illustration of adaptive acoustic feedback cancellation in a conference room environment.

where $a_k(m)$ are the coefficients of an all-pole linear feedback model of the reverberating room environment, G is the microphone–loudspeaker amplitude gain factor, and $x(m)$ and $y(m)$ are the time domain input and output signals of the microphone–loudspeaker system.

Figure 14.9 is an illustration of an acoustic feedback cancellation system. In an acoustic feedback environment, the total input signal to the microphone is given as the sum of any new input to the microphone $x(m)$ plus the unwanted acoustic feedback signal $y_f(m)$:

$$y(m) = x(m) + y_f(m) \quad (14.9)$$

The most successful acoustic feedback control systems are based on adaptive estimation and cancellation of the feedback signal. As in a line echo canceller, an adaptive acoustic feedback canceller attempts to synthesise a replica of the acoustic feedback at its output as

$$\hat{y}_f(m) = \sum_{k=0}^{P-1} \hat{a}_k(m) y(m-k) \quad (14.10)$$

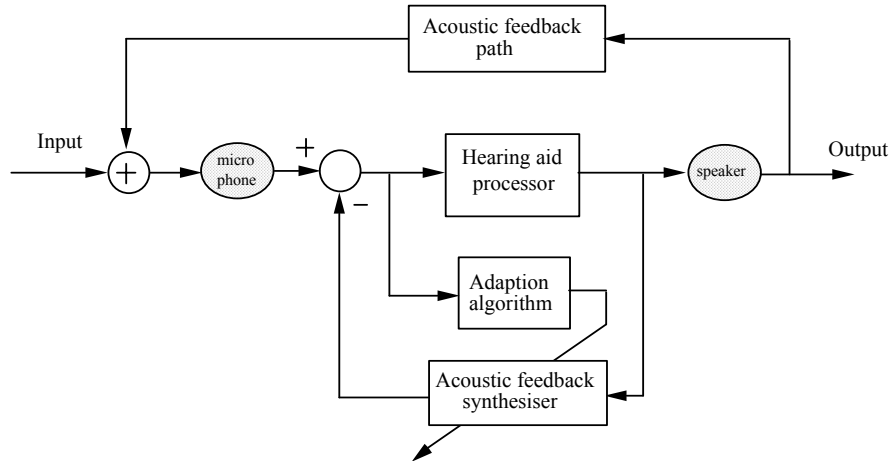

Figure 14.10 Configuration of an acoustic feedback canceller incorporated in a hearing aid system.

The filter coefficients are adapted to minimise the energy of an error signal defined as

$$e(m) = x(m) + y_f(m) - \hat{y}_f(m) \quad (14.11)$$

The adaptation criterion is usually the minimum mean square error criterion and the adaptation algorithm is a variant of the LMS or the RLS method. The problem of acoustic echo cancellation is more complex than line echo cancellation for a number of reasons. First, acoustic echo is usually much longer (up to a second) than terrestrial telephone line echoes. In fact, the delay of an acoustic echo is similar to or more than a line echo routed via a geostationary satellite system.

The large delay of an acoustic echo path implies that impractically large filters on the order of a few thousand coefficients may be required. The stable and speedy adaptation of filters of such length presents a difficult problem. Secondly, the characteristics of an acoustic echo path is more non-stationary compared with that of a telephone line echo. For example, the opening or closing of a door, or people moving in or out of a room, can suddenly change the acoustic character of a conference room. Thirdly, acoustic echoes are due to signals reflected back from a multitude of different paths, off the walls, the floor, the ceiling, the windows etc. Finally, the propagation and diffusion characteristics of the acoustic space of a room is a non-linear process, and is not well approximated by a lumped FIR (or

IIR) linear filter. In comparison, it is more reasonable to model the characteristics of a telephone line echo with a linear filter. In any case, for acoustic echo cancellation, the filter must have a large impulse response and should be able to quickly track fast changes in echo path characteristics.

An important application of acoustic feedback cancellation is in hearing aid systems. A hearing aid system can be modelled as a feedback system as shown in Figure 14.10. The maximum usable gain of a hearing aid system is limited by the acoustic feedback between the microphone and the speaker. Figure 14.10 illustrates the configuration of a feedback canceller in a hearing aid system. The acoustic feedback synthesiser has the same input as the acoustic feedback path. An adaptation algorithm adjusts the coefficients of the synthesiser to cancel out the feedback signals picked up by the microphone, before the microphone output is fed into the speaker.

14.6 Sub-Band Acoustic Echo Cancellation

In addition to the complex and varying nature of room acoustics, there are two main problems in acoustic echo cancellation. First, the echo delay is relatively long, and therefore the FIR echo synthesiser must have a large number of coefficients, say 2000 or more. Secondly, the long impulse response of the FIR filter and the large eigenvalue spread of the speech signals result in a slow, and uneven, rate of convergence of the adaptation process.

A sub-band-based echo canceller alleviates the problems associated with the required filter length and the speed of convergence. The sub-band-based system is shown in Figure 14.11. The sub-band analyser splits the input signal into N sub-bands. Assuming that the sub-bands have equal bandwidth, each sub-band occupies only $1/N$ of the baseband frequency, and can therefore be decimated (down sampled) without loss of information. For simplicity, assume that all sub-bands are down-sampled by the same factor R . The main advantages of a sub-band echo canceller are a reduction in filter length and a gain in the speed of convergence as explained below:

- (a) *Reduction in filter length.* Assuming that the impulse response of each sub-band filter has the same duration as the impulse response of the full band FIR filter, the length of the FIR filter for each down-sampled sub-band is $1/R$ of the full band filter.
- (b) *Reduction in computational complexity.* The computational complexity of an LMS-type adaptive filter depends directly on the

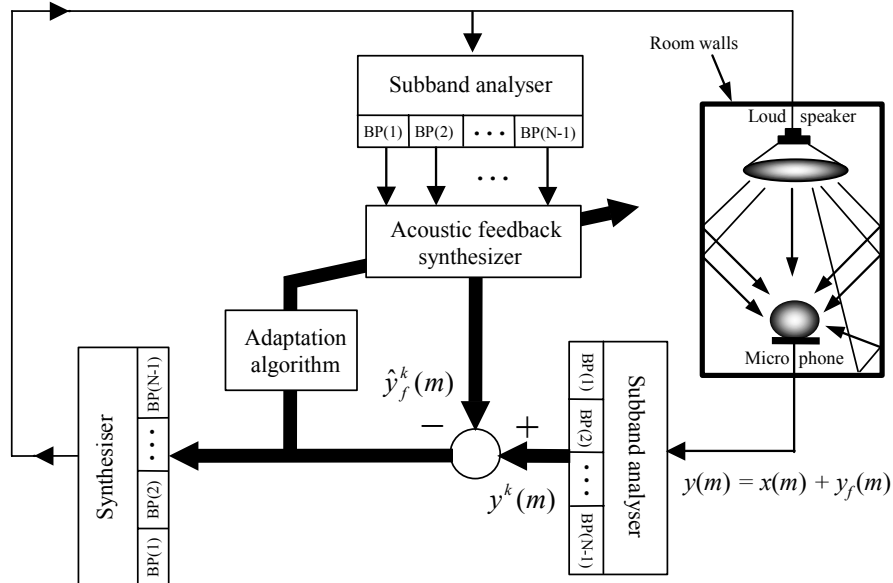

Figure 14.11 Configuration of a subband acoustic echo cancellation system.

product of the filter length and the sampling rate. As for each sub-band, the number of samples per second and the filter length decrease with $1/R$, it follows that the computational complexity of each sub-band filter is $1/R^2$ of that of the full band filter. Hence the overall gain in computational complexity of a sub-band system is R^2/N of the full band system.

- (c) *Speed of convergence.* The speed of convergence depends on both the filter length and the eigenvalue spread of the signal. The speed of convergence increases with the decrease in the length of the FIR filter for each sub-band. A more important factor affecting the convergence of adaptive filter is the eigenvalue spread of the autocorrelation matrix of the input signal. As the spectrum of a signal becomes flatter, the spread of its eigenvalues decreases, and the speed of convergence of the adaptive filter increases. In general, the signal within each sub-band is expected to have a flatter spectrum than the full band signal. This aids the speed of convergence. However, it must be noted that the attenuation of sub-band filters at the edges of the spectrum of each band creates some very small eigenvalues.

14.7 Summary

Telephone line echo and acoustic feedback echo affect the functioning of telecommunication and teleconferencing systems. In general, line echo cancellation, is a relatively less complex problem than acoustic echo cancellation because acoustic cancellers need to model the more complex environment of the space of a room.

We began this chapter with a study of the telephone line echoes arising from the mismatch at the 2/4-wire hybrid bridge. In Section 14.2, line echo suppression and adaptive line echo cancellation were considered. For adaptation of an echo canceller, the LMS or the RLS adaptation methods can be used. The RLS methods provides a faster convergence rate and better overall performance at the cost of higher computational complexity.

In Section 14.3, we considered the acoustic coupling between a loudspeaker and a microphone system. Acoustic feedback echo can result in howling, and can disrupt the performance of teleconference, hands-free telephones, and hearing aid systems. The main problems in implementation of acoustic echo cancellation systems are the requirement for a large filter to model the relatively long echo, and the adaptation problems associated with the eigenvalue spread of the signal. The sub-band echo canceller introduced in Section 14.4 alleviates these problems.

Bibliography

- ALLEN J., BERKLEY D. and BLAURET J. (1977) Multi-Microphone Signal Processing Technique to Remove Room Reverberation from Speech Signals. *J. Acoust. Soc. Am.*, **62**, 4.
- ARMBRUSTER W. (1992) Wideband Acoustic Echo Canceller with Two Filter Structure. *Proc. Eusipco-92*, **3**, pp. 1611–1617.
- CARTER G. (1987) Coherence and Time Delay Estimation. *Proc. IEEE*, **75**, **2**, pp. 236–55.
- FLANAGAN J.L. *et al.*, (1991) Autodirective Microphone systems. *Acoustica* **73**, pp.58–71.
- FLANAGAN J.L. *et al.*, (1985) Computer-Steered Microphone Arrays for Sound Transduction in Large Rooms. *J. Acoust. Soc. Amer.*, **78**, pp. 1508–1518.
- GAO X.Y. and SNELGROVE W.M. (1991) Adaptive Linearisation of a Loudspeaker, *IEEE. Proc. Int. Conf. Acoustics, Speech and Signal Processing, ICASSP-91*, **3**, pp. 3589-3592.

- GILLOIRE A. and VETTERLI M. (1994) Adaptive Filtering in Sub-bands with Critical Sampling: Analysis, Experiments and Applications to Acoustic Echo Cancellation, *IEEE. Trans. Signal Processing*, **40**, pp. 320–28.
- GRITTON C.W. and LIN D.W. (1984) Echo Cancellation Algorithms, *IEEE ASSP Mag.*, **1**, **2**, pp. 30–37.
- GUSTAFSSON S. and MARTIN R., (1997) Combined Acoustic Echo Control and Noise Reduction for Mobile Communications, *Proc. EuroSpeech-97*, pp. 1403–1406.
- HANSLER E. (1992) The Hands-Free Telephone Problem An Annotated Bibliography. *Signal Processing*, **27**, pp. 259–71.
- HART J.E., NAYLOR P.A. and TANRIKULU O. (1993) Polyphase Allpass IIR Structures for Subband Acoustic Echo Cancellation. *EuroSpeech-93*, **3**, pp. 1813-1816.
- HUA YE and BO-XIA WU (1991) A New Double-Talk Detection Algorithm Based on the Orthogonality Theorem. *IEEE Trans on Communications*, **39**, **11**, pp. 1542-1545, Nov.
- KELLERMANN W. (1988) Analysis and Design of Multirate Systems for Cancellation of Acoustical Echoes. *IEEE. Proc. Int. Conf. Acoustics, Speech and Signal Processing, ICASSP-88*, pp. 2570-73.
- KNAPPE M.E. (1992) Acoustic Echo Cancellation: Performance and Structures. M. Eng. Thesis, Carleton University, Ottawa, Canada.
- MARTIN R. and ALTENHONER J. (1995) Coupled Adaptive Filters for Acoustic Echo Control and Noise Reduction. *IEEE. Proc. Int. Conf. Acoustics, Speech and Signal Processing, ICASSP-95*, **5**, pp. 3043-46.
- McCASLIN S. R., HEMKUMAR N. and REDHEENDRAN B. (1997) Double-Talk Detector for Echo Canceller. US patent No. 5631900, May 20.
- OSLEN H.F. (1964) *Acoustical Engineering*, Toronto, D. Van Nostrand Inc.
- SCHROEDER M.R. (1964) Improvement of Acoustic-Feedback Stability by Frequency Shifting. *J. Acoust. Soc. Amer.*, **36**, pp. 1718-1724.
- SILVERMAN H.F. *et al.*, (1992) A Two-Stage Algorithm for Determining Talker Location from Linear Microphone Array Data. *Computer Speech and Language*, **6**, pp. 129-52.
- SONDHI M.M. and BERKLEY D.A.(1980) Silencing Echoes on the Telephone Network. *Proc. IEEE*, **68**, pp. 948-63.
- SONDHI M.M. and MORGAN D.R. (1991) Acoustic Echo Cancellation for Stereophonic Teleconferencing. *IEEE Workshop on Applications of Signal Processing to Audio And Acoustics*.
- SONDHI M.M. (1967) An Adaptive Echo Canceller. *Bell Syst. tech. J.*, **46**, pp. 497-511.

- TANRIKULU O., *etal.* (1995) Finite-Precision Design and Implementation of All-Pass Polyphase Networks for Echo Cancellation in subbands. IEEE. Proc. Int. Conf. Acoustics, Speech and Signal Processing, ICASSP-95, **5**, pp. 3039-42.
- VAIDYANATHAN P.P. (1993) Multirate Systems and Filter Banks. Prentice-Hall.
- WIDROW B., McCOOL J.M., LARIMORE M.G. and JOHNSON C.R. (1976) Stationary and Nonstationary Learning Characteristics of the LMS Adaptive Filters. Proceedings of the IEEE, **64**, **8**, pp. 1151-62.
- ZELINSKI R. (1988) A Microphone Array with Adaptive Post-Filtering for Noise Reduction in Reverberant Rooms. IEEE. Proc. Int. Conf. Acoustics, Speech and Signal Processing, ICASSP-88, pp. 2578-81.